

# KPAC1011

## Legend

- 1 Return Air
- 2 Control Pad
- 3 Cold Air Supply
- 4 Condenser Air Inlet
- 5 Condenser Air Outlet
- 6 Power Cord
- 7 Condensate Nipple
- 8 Condensate Alarm Jack
- 9 Access Door

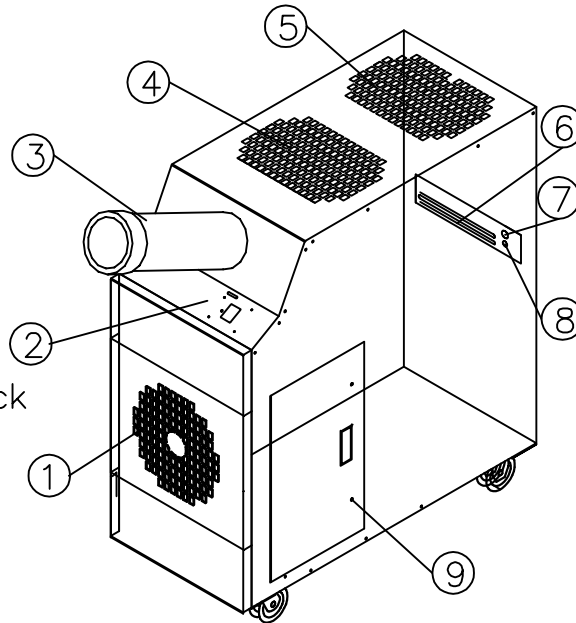

Isometric View

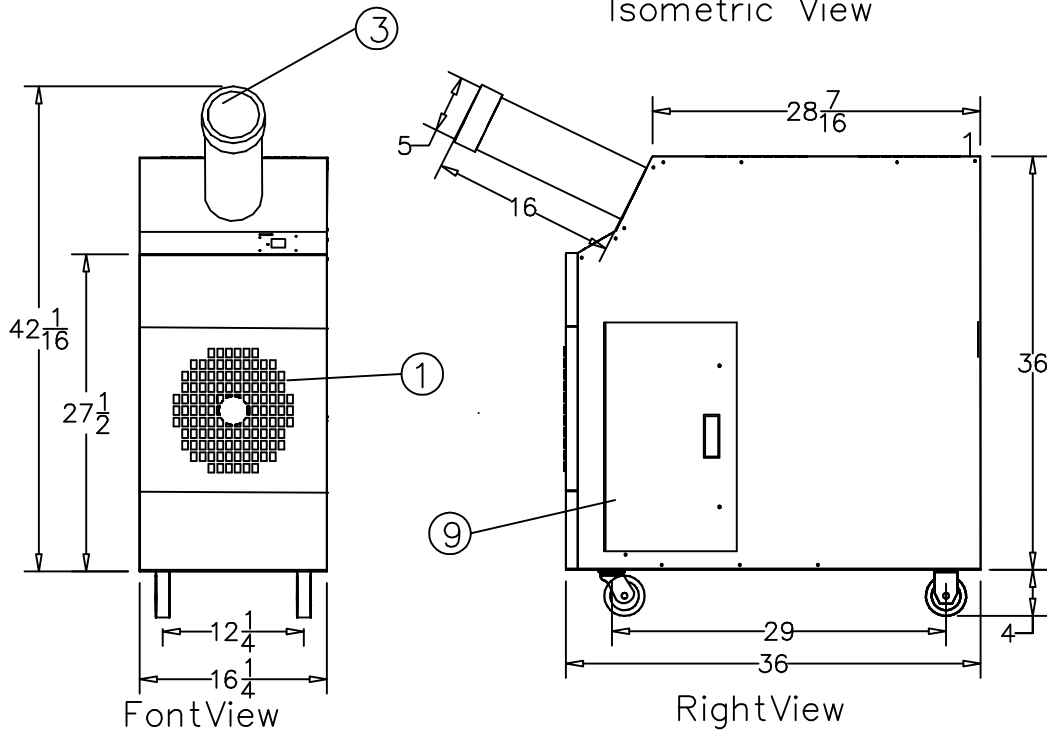

C US

ETL LISTED CONFORMS TO ANSI/UL  
1995 CERTIFIED TO CAN/CSAA22.2 NO.235

# SPECIFICATIONS

## Model KPAC1011 - 0.9 Ton

<b>COOLING CAPACITY</b>		
	BTU/hr @ 95 F at 60%RH	10,300 (.85 TON)
<b>COMPRESSOR DATA</b>		
	Compressor Type	HERMETIC ROTARY
	Operating Temperatures	70-110 F .50%RH
	Refrigerant	R-22
<b>FAN DATA</b>		
<b>EVAPORATOR</b>		
	Fan Type (Centrifigul)	DIRECT DRIVE
	Air Flow (CFM)	335/1
	Supply Air chute Data	1-5"Dia.x16"Length
	Supply Air Chute Max. Length	10'
	Motor HP	1/6
<b>CONDENSER</b>		
	I/O Intergral Condenser - In/Out	BALANCED AIR FLOW
	Fan Type (Centrifigul)	DIRECT DRIVE
	Air Flow (CFM)	1000
	Condenser Hose Data (Optional)	2x12"Dia.x8' Length
	Condenser Hose Max. Length	25'
	Motor HP	1/3
<b>ELECTRICAL DATA</b>		
	Power Supply (Volts)	115/10
	Current Consumption (Amps)	11.5
	Power Consumption (KW)	1.1
	Maximum Circuit Breaker (Amps)	15
	Minimum Circuit Ampacity (Amps)	13.12
	Min/Max Voltage	105-125
	Power Cord Gauge/Length	14 AWG/6'
	Plug Configruation	NEMA 5-15
<b>DIMENSIONAL DATA</b>		
Unitary Models	Width x Depth x Height (Inches)	16.25X36.5X40
	Weight (Lbs)	174
	Shipping Weight (Lbs)	249
	Ceiling Kit - CK-12 Weight	38
	Total Shipping Weight/w Ceiling Kit	302
<b>SAFETY DEVICE DATA</b>		
	Compressor Overload	INTERNAL
	Fan Motor Overload	AUTOMATIC INTERNAL
	Evaporator Freeze-up	FREEZE STAT
	High Pressure Switch	MANUAL
	Low Pressure Switch	AUTOMATIC
	Compressor Short Cycle	YES
	Automatic Restart	YES
	Thermostat	MICROPROCESSOR/ DIGITAL
	Condensate Pump w 20' Head Pres.	Optional
	Condensate Pump Overflow	Optional
	Condensate Tank Overflow	YES



**1-800-KWIKOOL**