

SWAC12043

Legend

- 1 Return Air
- 2 Control Pad
- 3 Cold Air Supply
- 4 Power Cord
- 5 1/2" Female water Hose Connector (Inlet/Outlet)
- 6 Condensate Nipple
- 7 Condensate Alarm Jack
- 8 Access Door

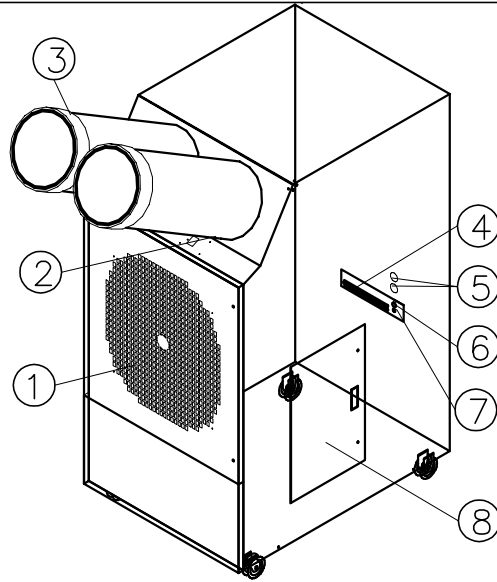

Isometric View

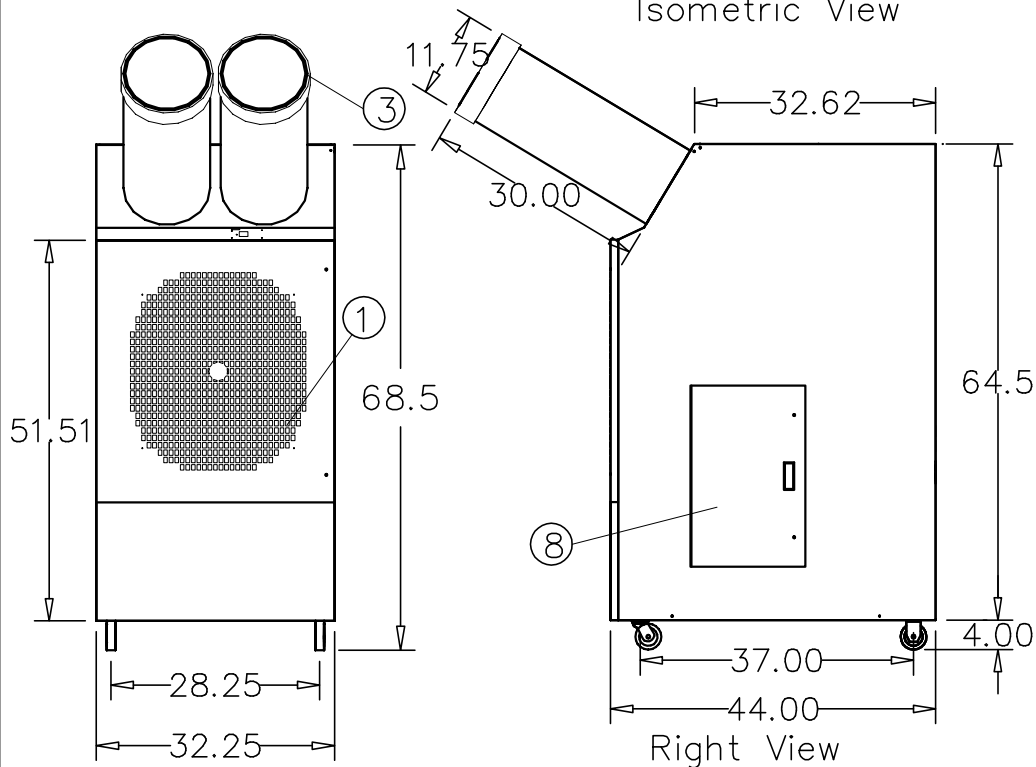

Front View

Right View



ETL LISTED CONFORMS TO ANSI/UL
1995 CERTIFIED TO CAN/CSAA22.2 NO.235



1-800-KWIKOOL

Model SWAC12043 - 10 Ton

COOLING CAPACITY		
	BTU/hr @ 95 F at 60%RH	120,000 (10 TONS)
COMPRESSOR DATA		
	Compressor Type, Quantity 2, 5-ton	HERMETIC RECIP./2 STAGE
	Operating Temperatures	60-110 F .50%RH
	Non-CFC Refrigerant Charge (Lbs.)	407C
FAN DATA		
EVAPORATOR		
	Fan Type (Centrifugal)	Belt Drive
	Air Flow (CFM)	1800/3800
	Supply Air Chute Data	2-12" Dia. x30" Length
	Supply Air Chute Max. Length	65'
	Motor HP	3
WATER FLOW DATA		
	Flow Regulation Valve	AUTOMATIC
	Inlet Water 85F-95F Exit(GPM)	30
	Inlet Water 75F-95F Exit(GPM)	15
	Inlet Water 65F-95F Exit(GPM)	10
	Inlet Water 55F-95F Exit(GPM)	7.5
	2 Separate Cooling Loops	2 Inlets & 2 Outlets
ELECTRICAL DATA		
	Power Supply (Volts)	460-3 Phase
	Current Consumption (Amps)	23.1
	Power Consumption (KW)	16.3
	Maximum Circuit Breaker (Amps)	30
	Minimum Circuit Ampacity (Amps)	69.7
	Min/Max Voltage	420-500
	Power Cord Gauge/Length	10AWG/10
	Plug Configuration	FIELD SUPPLIED
DIMENSIONAL DATA		
Unitary Models	Width x Depth x Height (Inches)	32.25X44X68.5
	Weight (Lbs.)	750
	Shipping Weight (Lbs.)	825
SAFETY DEVICE DATA		
	Compressor Overload	INTERNAL
	Fan Motor Overload	AUTOMATIC INTERNAL
	Evaporator Freeze-up	HOT GAS BYPASS
	High Pressure Switch	MANUAL
	Low Pressure Switch	AUTOMATIC
	Compressor Short Cycle	YES
	Automatic Restart	YES
	Thermostat	MICROPROCESSOR/ DIGITAL
	Condensate Pump w 20' Head Pres.	YES
	Condensate Pump Overflow	YES
	Condensate Tank Overflow	YES



1-800-KWIKOOL