

# KPAC II

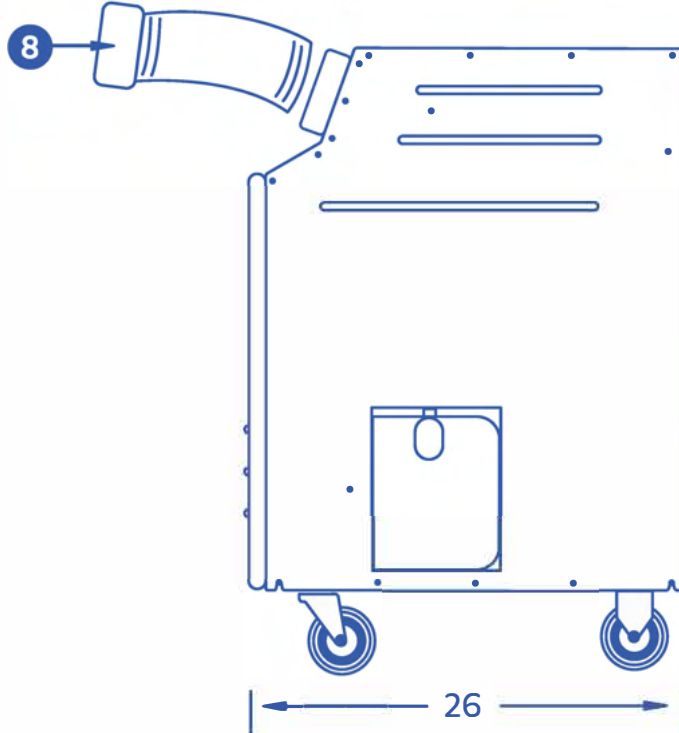

## KPAC 2421-2

- |                        |   |
|------------------------|---|
| 1) Cold Air Return     | 5) Condensate Air Outlet                  |
| 2) Control Pad         | 6) Power Cord                             |
| 3) Cold Air Supply     | 7) Condensate Tank                        |
| 4) Condenser Air Inlet | 8) Air Chutes (Attach To Cold Air Supply) |

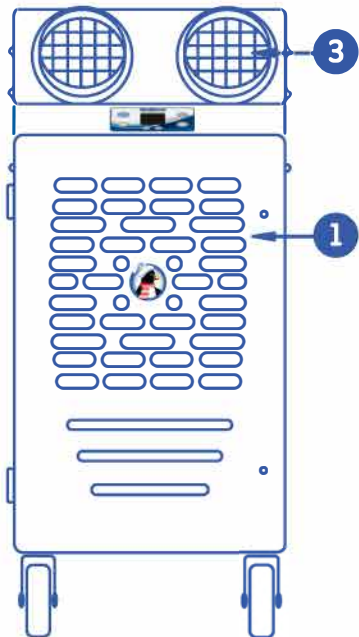
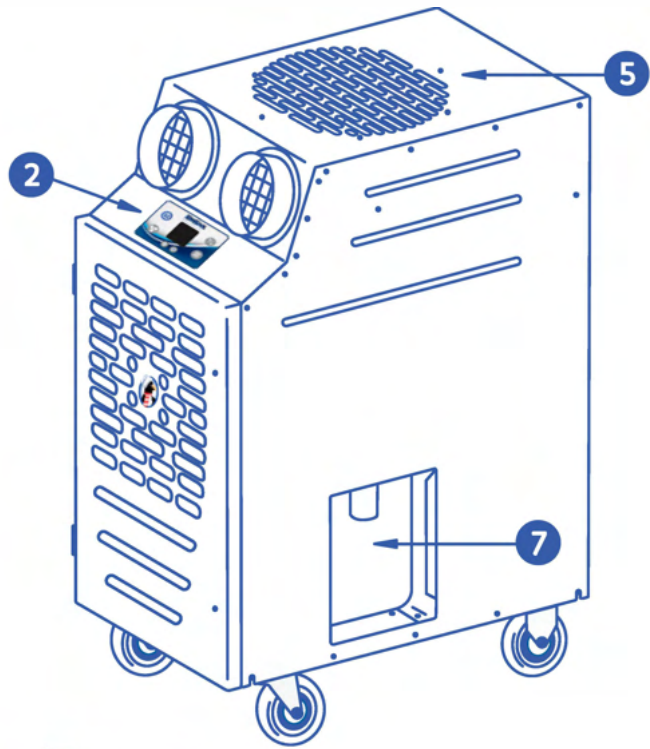
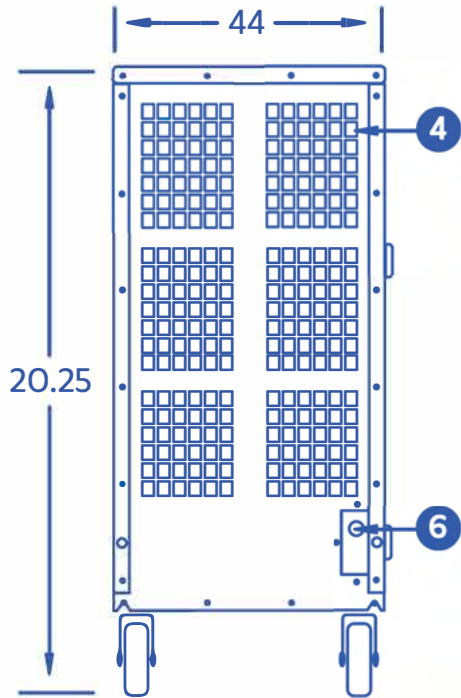

ETL LISTED CONFORMS TO ANSI/UL1995  
CERTIFIED TO CAN/CSA 22.2 NO 235

**KWIKOOL.COM**

# KPAC II



## KPAC 2421-2 AIR COOLED PORTABLE

### COOLING CAPACITY

BTU/hr @95 F at 60%RH 22,900 / 2-Ton

### COMPRESSOR DATA

Compressor Type Hermetic Rotary  
Operating Temperatures 40-105°F 50% RH  
Non-CFC Refrigerant 410A

### FAN DATA EVAPORATOR

Fan Type (Centrifugal) Direct Drive  
Air Flow (CFM) 810 / Single Speed  
Supply Air Control Adjustable Vent  
Supply Air Chute 2 - 6" dia x 18' (25' max length)

### CONDENSER WATER FLOW

Fan Type (Centrifugal) Direct Drive  
Air Flow (CFM) 1100  
Condenser Duct Specs (optional) 1 - 14" Dia. x 8' length  
Condenser Duct Max Length 25'

### ELECTRICAL DATA

Power Supply 208 / 230 V / Single Phase  
Current Consumption 10.6 / 9.6 Amps  
Power Consumption 1.99 kW  
Maximum Circuit Breaker 20 Amps  
Recommended Breaker Size 20  
Minimum Circuit Ampacity 14.3 Amps  
Min/Max Voltage 195 - 225  
Power Cord Gauge / Length in Feet 12 AWG / 8'  
Plug Configuration NEMA 6 - 20

### DIMENSIONAL DATA

Width x Length x Height 20.325" x 26" x 44"  
Weight 206 lbs.  
Shipping Weight 266 lbs.  
Ceiling Kit 24 lbs.  
Shipping Weight W/ Ceiling Kit 290 lbs.

### SAFETY DEVICE DATA

Compressor Overload Internal  
Fan Motor Overload Automatic Internal  
Evaporator Freeze Guard Freeze Stat  
High Pressure Switch Manual  
Low Pressure Switch Auto  
Compressor Short Cycle Yes  
Automatic Restart Yes  
Thermostat Type Digital Microprocessor  
Condensate Pump Overflow Optional  
Condensate Tank Overflow Yes



We Manufacture Excellent Commercial Portable Cooling Equipment.

1-800-kwikool | sales@kwikool.com